

Performance Analysis of IEEE 802.15.4 Propagation Parameters

Nidal AbidAl-Hamid Al-Dmour

Faculty of Informaion Technology, Ajman University of Science and Technology, Ajman, PO (346), UAE

Corresponding Email : (n.aldmour@ajman.ac.ae)

Abstract— *The IEEE 802.15.4 protocol has the ability to support Low Rate Wireless Personal Area Networks (WPANs) with very low power consumption time-sensitive. In this paper, we have analyzed the effect of size of the network, duty cycle, beacon fraction, and transmitted power on the value propagation between nodes in wireless sensor network that uses IEEE 802.15.4 MAC. Specifically, we have used Omnet++ simulator and Castalia to study the impact of varying these parameters on value propagation between nodes.*

Keywords— Wireless Network, IEEE 802.15.4, Castalia, Beacon Fraction, Duty Cycle, and Omnet++.

I. Introduction

Wireless Personal Area Network (WPAN) is centered around user workspace that typically extends up to 10m in all directions [1]. The main characteristics* of WPAN are: low-cost, low power, short range and very small size. The IEEE 802.15 working group has defined three classes of WPANs that are differentiated by data rate, battery drain and Quality of Service(QoS). These classes are:

1. IEEE 802.15.3: The IEEE 802.15.3 is designed for high data rate WPAN and suitable for multi-media applications that require very high QoS [3].
2. IEEE 802.15.1/Bluetooth: The 802.15.1 is designed for medium rate WPANs for handling a variety of tasks ranging from cell phones to PDA communications and provides QoS suitable for voice communications [4].
3. IEEE 802.15.4: IEEE 802.15.4 is designed for low rate WPANs and it is intended to serve a set of industrial, residential and medical applications with very low power consumption [5].

The IEEE 802.15.4 has many features that are not considered by IEEE 802.15.1 and IEEE 802.15.3. The low data rate enables the IEEE 802.15.4 to consume very little power. In year 2000, Zigbee and IEEE 802 work group worked together to address the need for low cost and low power consumption [6]. ZigBee technology is a low data rate, low power consumption, low cost, and wireless networking protocol targeted towards automation and remote control applications. Zigbee has been considered as an alternative for WPAN.

The IEEE 802.15.4 has presented two medium-access modes: Non Beacon-enabled mode and Beacon-enabled mode. In networks without beacons, unslotted or standard CSMA-CA is used. In a beacon-enabled network with superframes, a Slotted Carrier Sense Multiple Access with Collision Avoidance (CSMA-CA) mechanism is used. We focus in this paper on the IEEE 802.15.4 beacon-enabled mode, and the details for the non beacon-enabled mode can be found in [5].

The Medium Access Control protocol is an important part of the node's behaviour, thus there is a separate module that defines it. Castalia has defined four main MAC modules: 1)

TunableMAC, a duty-cycled MAC which exposes many parameters to the user and the application for tuning. From TunableMAC we also get the behaviour of a simple CSMA/CA MAC protocol. 2) the popular TMAC. From TMAC we can also get S-MAC by just setting couple of parameters (T-MAC is an enhancement of S-MAC allowing extendible active times). 3) IEEE 802.15.4 MAC. This is the standard for low power wireless networks, although *not* prevalent in WSN. 4) IEEE 802.15.6 MAC draft proposal for Body Area Networks (BAN).

This paper illustrates the affect of size of the network, duty cycle, beacon fraction, and transmitted power on the value propagation between nodes in wireless sensor network that uses IEEE 802.15.4 MAC. We used Omnet++ simulator [15] in addition to Castalia [17] simulation model to study the impact of varying these parameters.

The rest of this paper is organized as follows: Section two presents the research methodology. In Section three, our simulation results are presented after conducting a series of experiments. Section four is the conclusion.

II. RESEARCH METHODOLOGY

In order to study the impact of varying size of the network, duty cycle, beacon fraction, and transmitted power on the value propagation between nodes a simulation tool was required. There were several simulation tools that could have been used. Examples of these tools are: Global Mobile Information Systems Information Library (GloMoSim) [11] and [12], Optimised Network Engineering Tools (OPNET) [13], Network Simulator (NS-2) [14], and Omnet++ [15]. Omnet++ can support a large number of network components such as different applications, protocols, and traffic models.

Omnet++ is a public-source, component-based, and modular simulation framework. It is mostly applied to the domain of network simulation and other distributed systems. The Omnet++ model is composed of hierarchically nested modules. The top-level module is called the Network Module. This module contains one or more sub-modules each of which could contain other sub-modules. Various Internet protocol model have been developed on the top of Omnet++ such as the Omnet++ Mobility Framework [16] and Castalia [17].

Castalia can be used to test distributed algorithms and/or protocols in realistic wireless channel and radio models. It can also be used to evaluate different platform characteristics for specific applications, since it is highly parametric, and can simulate a wide range of platforms. Castalia's basic module structure is shown in figure 1. The nodes in Castalia are not

connected with each other, but they are connected through the wireless channel [17]. The wireless channel is responsible for delivering for example a packet from one node to another. The nodes are also linked through the physical processes that they monitor. The nodes sample the physical process in space and time to get their sensor readings.

A simulation model was built by using both Omnet++ and Castalia to study the affect of size of the network, duty cycle, beacon fraction, and transmitted power on the value propagation between nodes in wireless sensor network that uses IEEE 802.15.4 MAC. A configuration file named *omnetpp.ini* was built which is shown in figure 2.

III. SIMULATION RESULTS

In our simulation scenarios we assume that each node sample their temperature sensor periodically. If a sensed value is above the threshold of 15 degree then this value need to be broadcasted. Additionally, a node receives this value any from its neighbouring nodes tries to broadcast it. The value is propagated depend on the condition of the channel between nodes. In our simulation scenarios, Node 0 is the only node that measures the temperature and propagate this value if its above the threshold. A node is reporting 1 if a node has a value above the threshold where this value is obtained either by sensing or received from any of its neighbouring nodes. It also reports 0 if its below the threshold.

We have run different simulation scenarios by using Castalia and we have varied the following parameters:

1. The size of the network was as follows:
 - a. 4 nodes by 4 nodes
 - b. 5 nodes by 5 nodes
 - c. 6 nodes by 6 nodes
2. The beacon fraction which represents how often each node sends a beacon to confirm their presence to other nodes and it has the following values: 0.2, 0.4, 0.6, and 0.8.
3. The duty cycle for each node also varies as follows : 0.1, 0.2, 0.3, 0.4, and 0.5.
4. The power of transmission of each node as follows: -1 dbm, -5 dbm, and -10 dbm.

Figures 3, 4, and 5 show the propagation metrics as we varied the above parameters. The figures show that as the size of the network increases the got values results decreases. Additionally, the figures show that increasing the duty cycle doesn't always improve the get value results whereas the increase of beacon fraction has significantly increased the get value results.

IV CONCLUSIONS

The IEEE 802.15.4 defines two medium-access modes: Non beacon-enabled mode and Beacon-enabled mode. We focused in this paper on the IEEE 802.15.4 beacon-enabled mode. We analyzed the affect of size of the network, duty cycle, beacon fraction, and transmitted power on the value propagation between nodes in wireless sensor network that uses IEEE 802.15.4 MAC. Specifically, we have used Omnet++ simulator and Castalia to study the impact of varying these parameters on value propagation between nodes.

REFERENCES

- i. N. Torabi, W. Wong, and V. Leung, 2011. *A Robust Coexistence Scheme for IEEE 802.15.4 Wireless Personal Area Networks Consumer*. In the *Communications and Networking Conference (CCNC)*.
- ii. T. Slep, I. Gifford, R. Braley, and R. Heile, 2000. *Paving the Way for Personal Area Network Standards: an Overview of the IEEE P802.15 Working Group for Wireless Personal Area Networks Personal Communications, Volume: 7, Page(s): 37 – 43*.
- iii. IEEE Standard for Information Technology Part 15.3: *Wireless Medium Access Control (MAC) and Physical Layer (PHY) Specifications for Wireless Personal Area Networks (WPANs)*, IEEE Standard 802.15.3 Working Group Std., 2003.
- iv. Bluetooth SIG. *Bluetooth Specification*. 1999.
- v. IEEE Standard for Information Technology Part 15.4: *Wireless Medium Access Control (MAC) and Physical Layer (PHY) Specifications for Low-Rate Wireless Personal Area Networks (LR-WPANs)*, IEEE Standard 802.15.4 Working Group Std., 2003.
- vi. N. Vljajic, D. Stevanovic, G. Spanogiannopoulos, 2011. *Strategies for Improving Performance of IEEE 802.15.4/ZigBee WSNs with Path-constrained Mobile Sink(s)*. *Computer Communications, Volume 34, Issue 6, Pages 743-757*.
- vii. J. Zheng and M. Lee, 2004. *Will IEEE 802.15.4 Make Ubiquitous Networking a reality?: a Discussion on a Potential Low Power, Low Bit Rate Standard*. *Communications Magazine, IEEE*.
- viii. G. Lu, B. Krishnamachari, and C. Raghavendra, 2004. *Performance Evaluation of the IEEE 802.15.4 MAC for Low-rate Low-Power Wireless Networks*. In the *Proceedings of the 23rd IEEE International Performance, Computing and Communications Conference (IPCCC)*.
- ix. N. Timmons and W. Scanlon, 2004. *Analysis of the Performance of IEEE 802.15.4 for Medical Sensor Body Area Networking*. *IEEE SECON 2004*.
- x. J. Mi'si'c, V. Mi'si'c, and S. Shafi, 2004. *Performance of IEEE 802.15.4 Beacon Enabled PAN with Uplink Transmissions in Nonsaturation Mode - Access Delay for Finite Buffers*. In the *Proceedings of the First International Conference on Broadband Networks (BROADNETS04)*.
- xi. GloMoSim, *Global Mobile Information System Simulation Library*, [online]. Last accessed on 7 April 2011 at: <http://pcl.cs.ucla.edu/projects/glomosim/>.
- xii. Z. Xiang., R. Bagrodia, and M. Gerla, 1998. *GloMoSim: A Library for Parallel Simulation of Large-Scale Wireless Networks*. In the *Proceedings 12th Workshop on Parallel and Distributed Simulations (PADS98)*, IEEE Computer Society Press, Page(s): 154-161.
- xiii. OPNET, [online]. Last accessed on 7 May 2011 at: <http://www.opnet.com/>
- xiv. NS-2, *Network Simulator 2*, [online]. Last accessed on 20 May 2011 at: <http://www.isi.edu/nsnam/ns>.
- xv. Omnet++, *Discrete Event Simulation System*, [online]. Last accessed on 20 May 2011 at: <http://www.omnetpp.org/>.
- xvi. Mobility Framework for OMNeT++, [online]. Last accessed on 20 May 2011 at: <https://github.com/mobility-fw/mf-opp4/wiki>
- xvii. Castalia, *A simulator of WSNs*, [online]. Last accessed on 20 May 2011 at: <http://castalia.npc.nicta.com.au/>

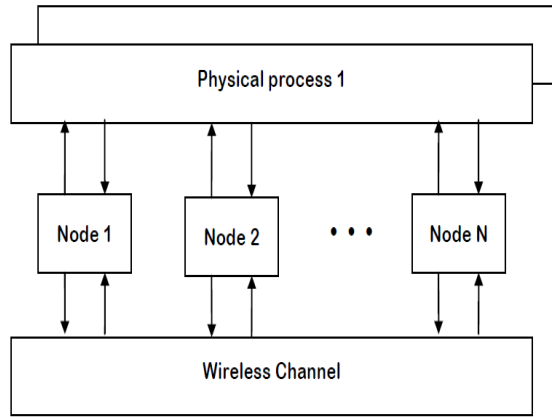

Fig.1: The modules and their connections in Castalia [17].

```

SN.numNodes = 16
SN.deployment = "4x4"

include ../Parameters/PhysicalProcess/node0_assignedValue40.ini

SN.node[*].Communication.Radio.RadioParametersFile =
"./Parameters/Radio/CC2420.txt"
SN.node[*].Communication.MACProtocolName = "TunableMAC"
SN.node[*].ApplicationName = "ValuePropagation"

SN.node[*].Communication.MAC.listenInterval = 10
SN.node[*].Communication.MAC.dutyCycle = 0.1
SN.node[*].Communication.MAC.beaconIntervalFraction = 1.0

SN.node[*].Communication.Radio.TxOutputPower = "0dBm"

[Config varyDutyCycle]
SN.node[*].Communication.MAC.dutyCycle = ${dutyCycle= 0.02, 0.05, 0.1}

[Config varyBeacon]
SN.node[*].Communication.MAC.beaconIntervalFraction = ${beaconFraction= 0.2, 0.5,
0.8}

[Config varyTxPower]
SN.node[*].Communication.Radio.TxOutputPower = ${TXpower="-1dBm","-5dBm"}

[Config debug]
SN.node[*].Communication.MAC.collectTraceInfo = true
SN.node[*].Application.collectTraceInfo = true

[Config naiveChannel]
SN.wirelessChannel.sigma = 0
SN.wirelessChannel.bidirectionalSigma = 0

[Config beaconSize]
# have at least 2 beacons in a listening interval
# default is 125 bytes -> 4.2msec TX time-> 2.4 beacons in 10ms
SN.node[*].Communication.MAC.beaconFrameSize = 50 # in bytes
    
```

Fig. 2: The configuration file *omnetpp.ini*.

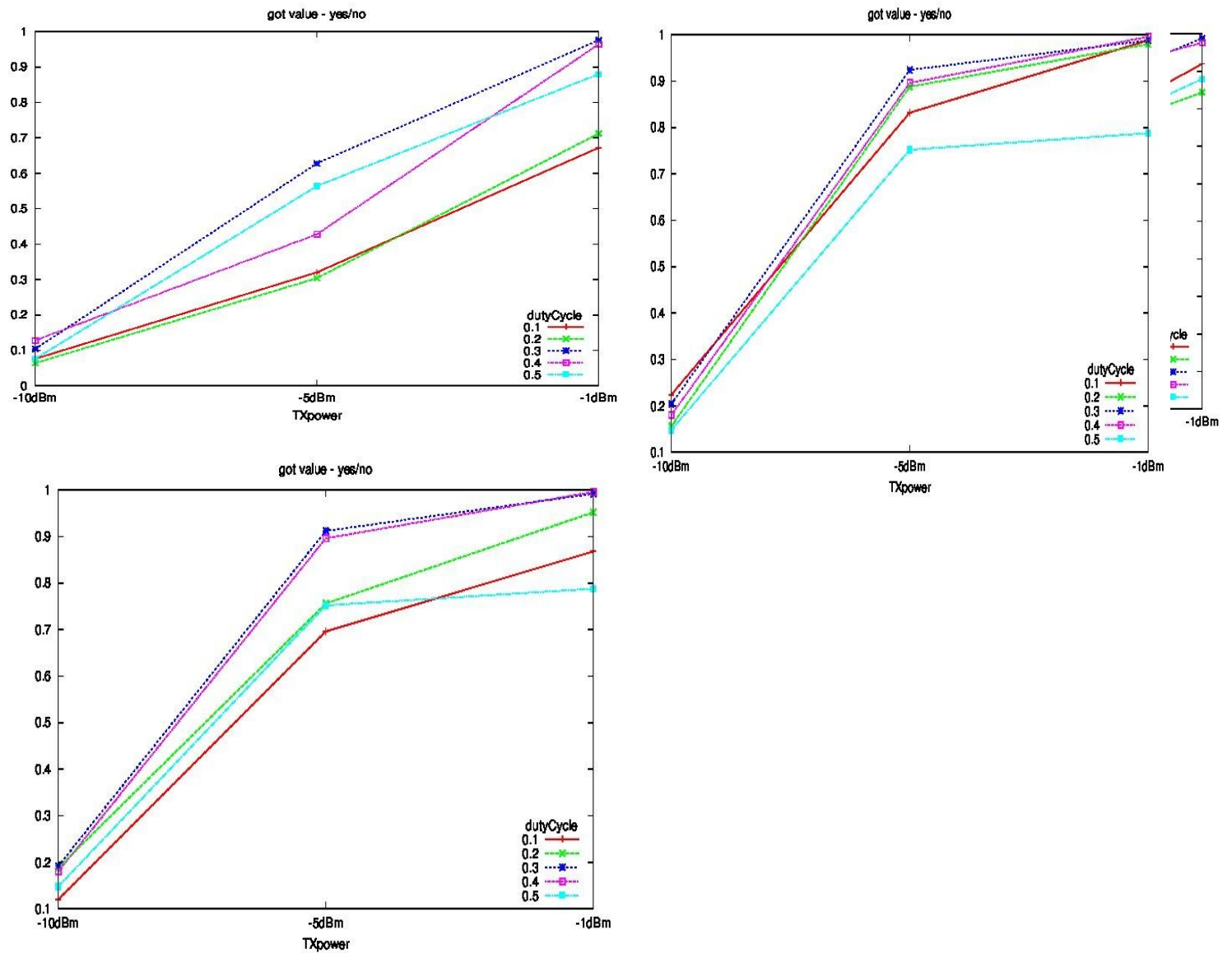

Fig. 3: Shows the propagation metrics for a network with 16 nodes and beacon fraction of values: a) 0.2, b) 0.4, c) 0.6, and d) 0.8.

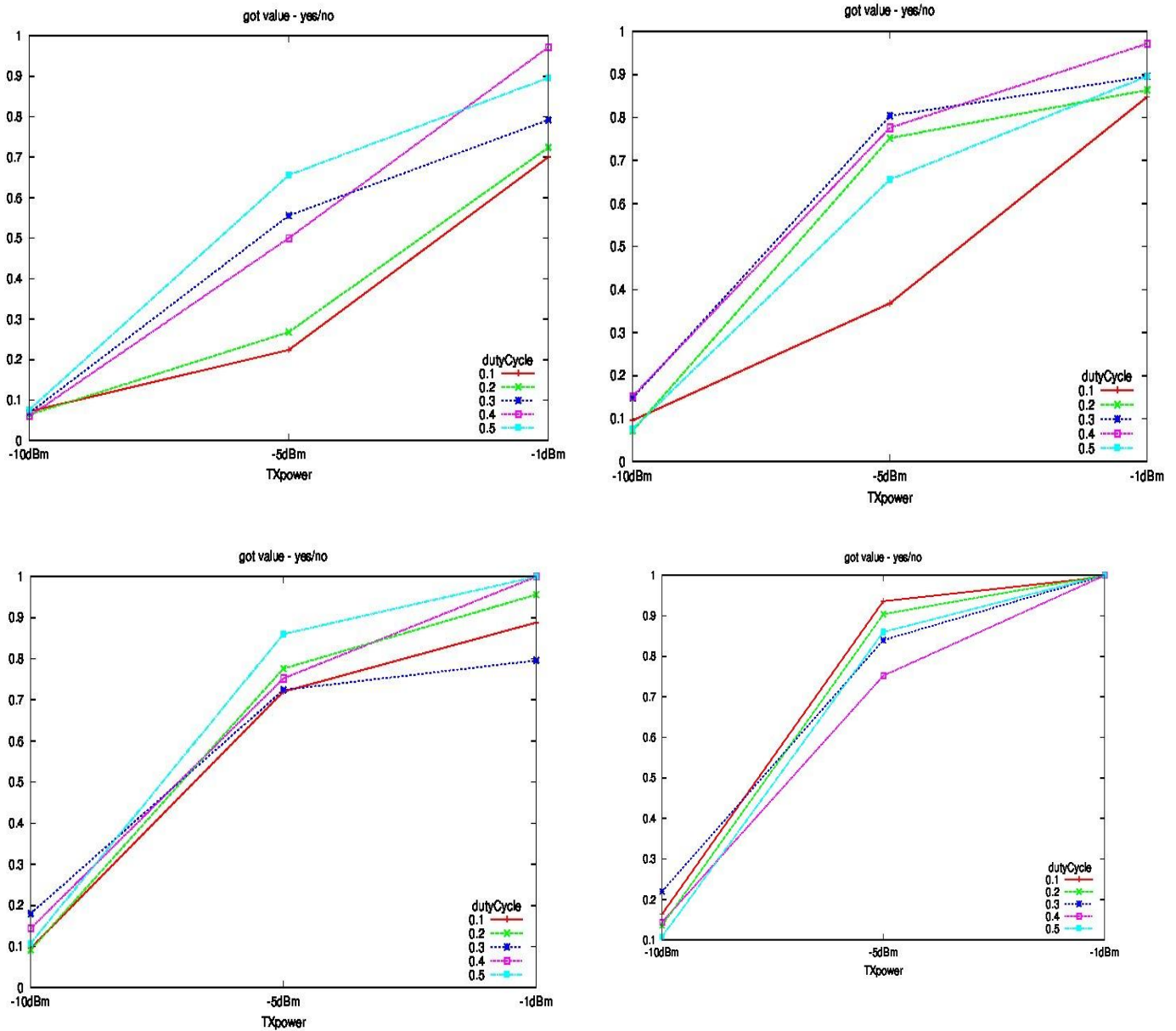

Fig. 4: Shows the propagation metrics for a network with 25 nodes and beacon fraction of values: a) 0.2, b) 0.4, c) 0.6, and d) 0.8.

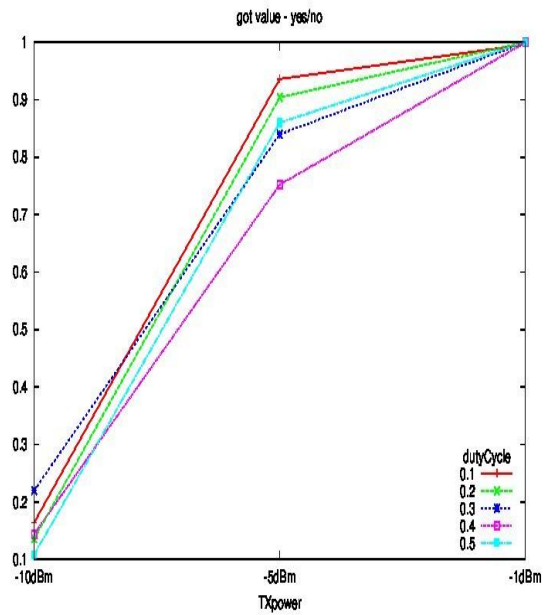
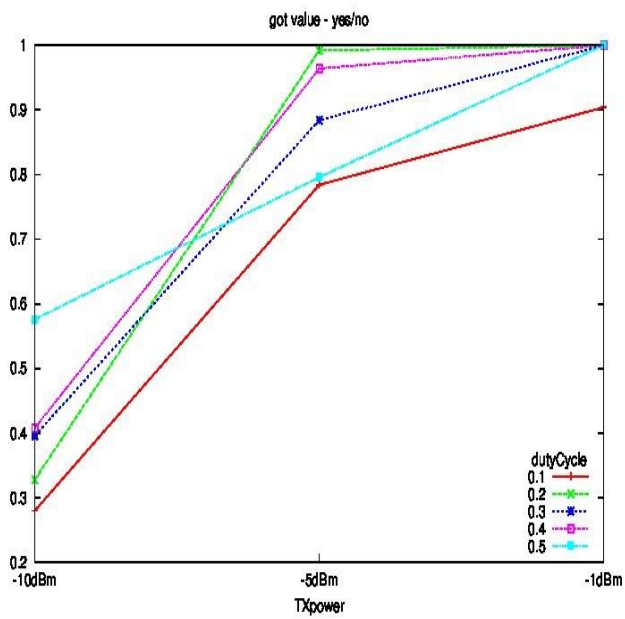
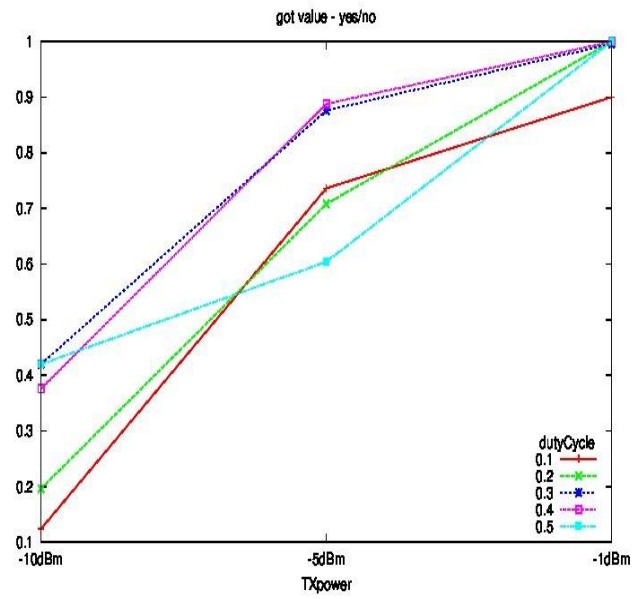
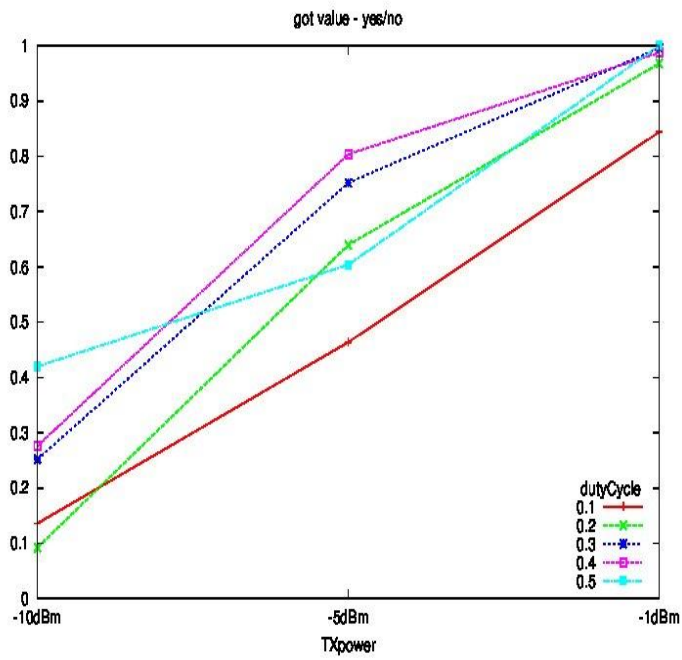

Fig. 5: Shows the propagation metrics for a network with 36 nodes and beacon fraction of values: a) 0.2, b) 0.4, c) 0.6, and d) 0.8.